

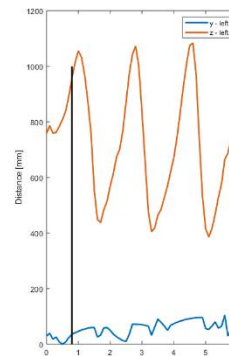

## SILENSE | (ultra)Sound Interfaces and Low Energy iNtegrated SENSors

### PROJECT NEWS

**S**ILENSE project comes to its end. All the partners are now focusing on the last review meeting planned on June 23<sup>rd</sup>/24<sup>th</sup>. In previous newsletters we described underwater solutions, automotive domain and applications of ultrasound technology in the field of smart home and buildings. The wearable systems, last not mentioned part of the project, is in focus in this newsletter. Three SILENSE project use cases will be presented. The first one is very complex smart acoustic wearable system for smart retail, which can be divided into four major parts. Another two use cases which are presented are motion tracking for sports and rehabilitation and multi-purpose (arm) gesture recognition.

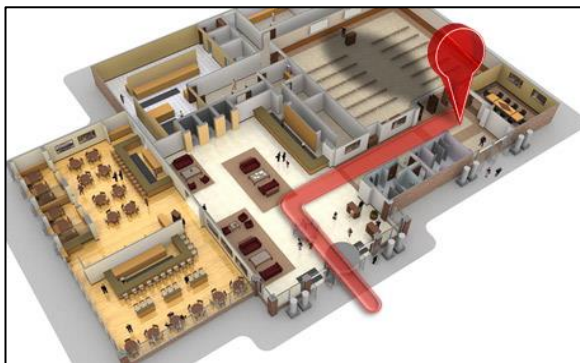

### SMART ACOUSTIC WEARABLE SYSTEM

In the retail use-cases the smart acoustic wearable system is intended to help customer find goods and navigate them indoor. To work properly it needs to pair automatically to retail Wi-Fi, locate itself, communicate with user by haptic feedback and acquire customer orders by gestures or voice.

This system consists of four sub-systems which can be integrated into smartphone or smart watch:

- Indoor navigation and device pairing
- Gesture recognition
- Low power speech user-interface
- Haptic feedback

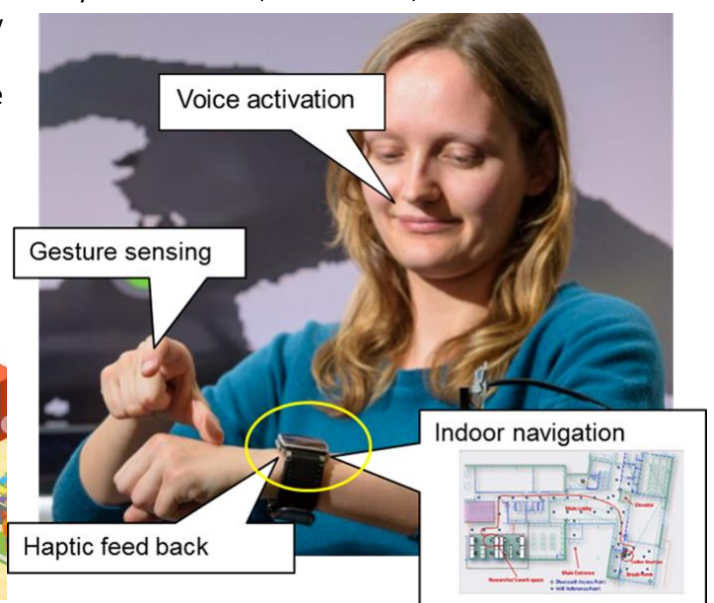

## INDOOR NAVIGATION AND DEVICE PAIRING

Last thing anyone want to do is to look up for the right Wi-Fi network when entering a shop. Project partner TNO developed narrow-band system for wake-up of smartphone or smartwatch. The device ultrasound pairing can be then used to exchange a key of the local Wi-Fi network when entering the room and a safe connection can be set up.

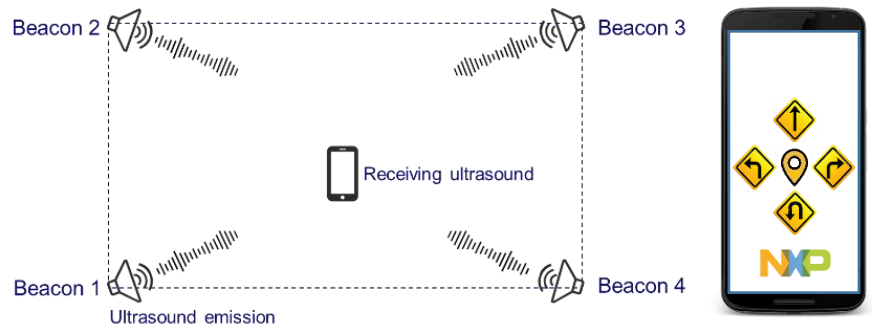

NXP used ultrasound beacons for indoor localization, sort of 'indoor GPS', therefore a customer can find his position on a map or can be guided to searched product.

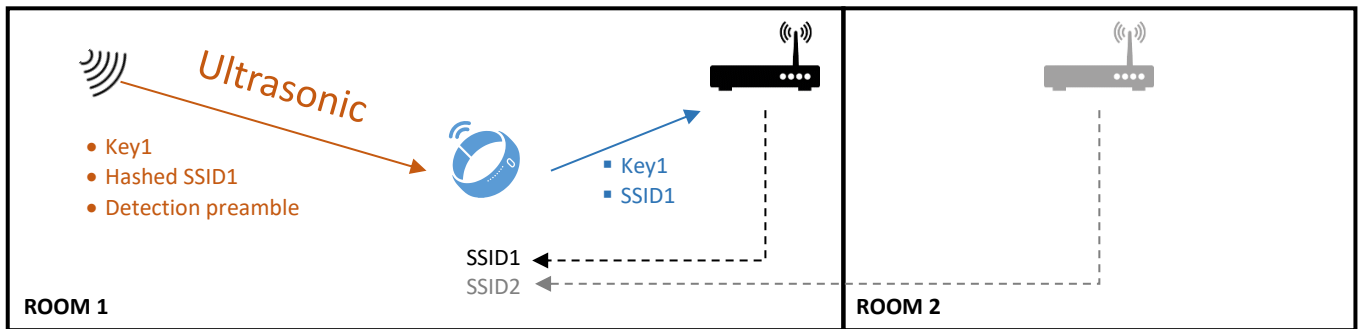

## GESTURE RECOGNITION

Easy way of communication with a small device can be achieved by use of gestures. For instance, any gesture that does not depend on finger resolution can still represent many possibilities such as:

- In-air press-hold-release using a hand.
- Variable hand speed gestures.
- Swipes in any direction.

Project partner TU/e made these gesture classifications possible. IMEC and TUB developed fine gesture recognition with the possibility to resolve the individual fingers using pMUT transducer array.

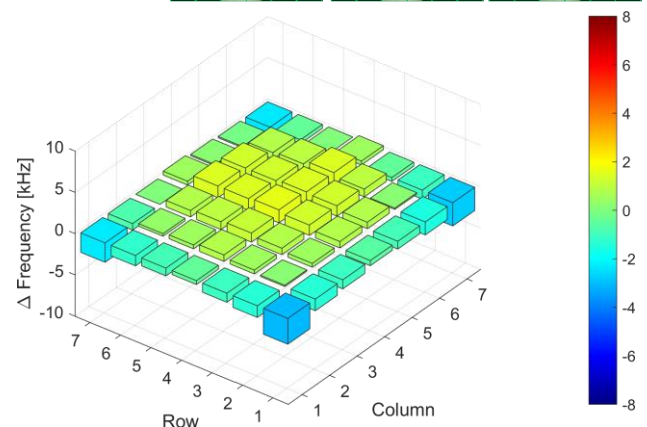
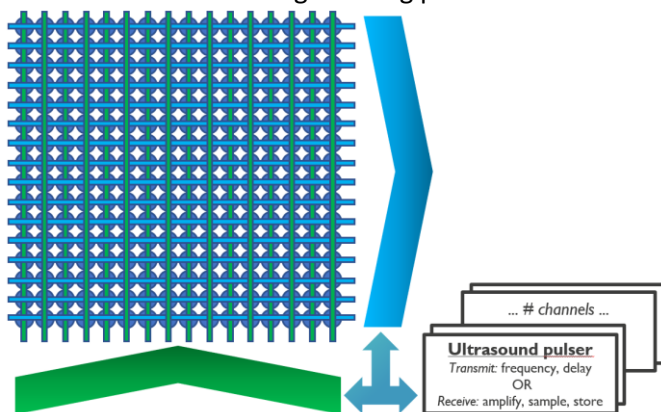
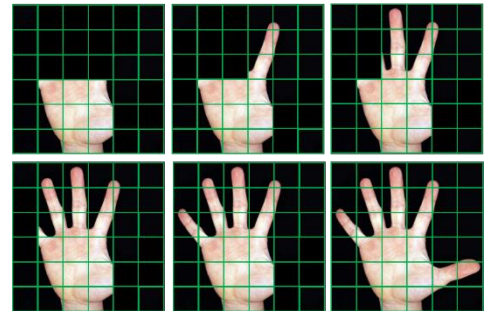

### LOW POWER SPEECH USER-INTERFACE

Next thing you would like to use as a customer is to order what you are looking for. NXP and CEA Leti developed a low power speech user interface to interact with devices by the voice. The interaction is split in two phases, the wake-up word (to wake up the device) and the voice command to send an intent action. To reduce the power consumption of the wake-up word detection, some implementation of the feature extraction part was realised as the analog pre-processing so more power scalability is possible even before transforming the voice to digital signal.

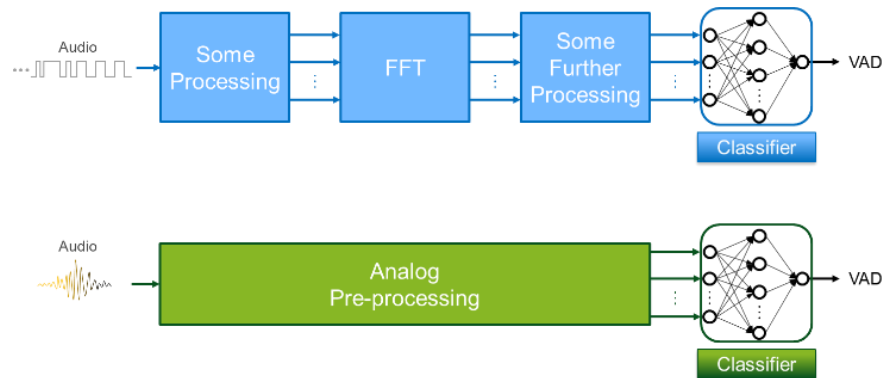

### HAPTIC FEEDBACK

Some sort of user informing is needed. NXP enhanced contact-based haptic. Tactile haptic patterns can notify the customer about the directions to take in order to get to the desired location. These patterns are generated using a Smart Haptic amplifier integrated in a smartphone or smartwatch. It can generate sharp and strong haptic vibrations from any existing haptic transducer.

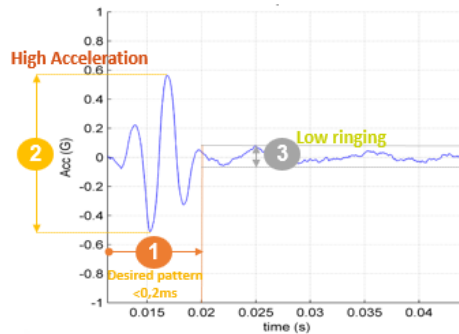

TNO developed mid-air haptic feedback using novel printed polymer transducers. Once the user has reached the location of the requested product, mid-air haptic feedback is used to interact with the customer. The mid-air haptic devices can be integrated in a shelf, thereby creating a 'smart shelf'. Important aspect is the form factor of the haptic actuators: they should be thin in order to be integrated seamlessly into the environment. The thin film printed transducers on thin plastic film will do just that.

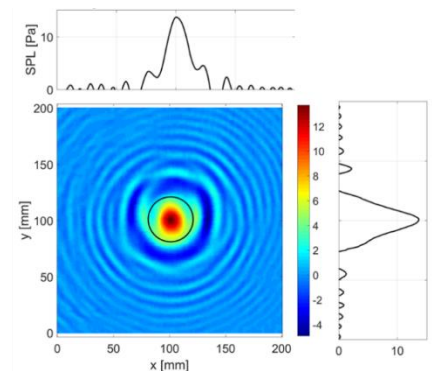



## HUMAN MOTION-TRACKING FOR SPORTS AND REHABILITATION

Enhancing the precision of existing sensors for human motion tracking is possible by ultrasound. SINTEF develops a motion tracking system combining ultrasound time-of-flight (ToF) measurements with motion sensors, also called inertial measurement units (IMUs), to provide better accuracy and automatic calibration for human motion tracking. IMUs are routinely used for gait analysis, but they suffer from measurement drift over time. Additionally, IMUs placed on different locations on the body do not give any information on the relative position of the different IMUs.

Ultrasound ToF measurements are used to compensate drift, as well as to provide the missing information needed in order to quantify the relative distances between individual IMUs. The accurate measurements of relative distances between the IMUs, positioned at different body segments, enable the creation of an automatic body coordinate system.

Two use cases are in focus: persons with multiple sclerosis (MS) and sport athletes. The use of IMUs together with ultrasound ToF measurements can give an improved and more detailed and patient-specific gait analysis, compared to the standard test. The measured gait will be visualized to the user in form of a stickman, to make the measured motion easy to understand and analyse, and thereby help to improve the rehabilitation and therapy for each patient. The aim is that this system will be useful also for top athletes to analyse e.g. their running technique and improve their performance by optimizing their motion patterns.

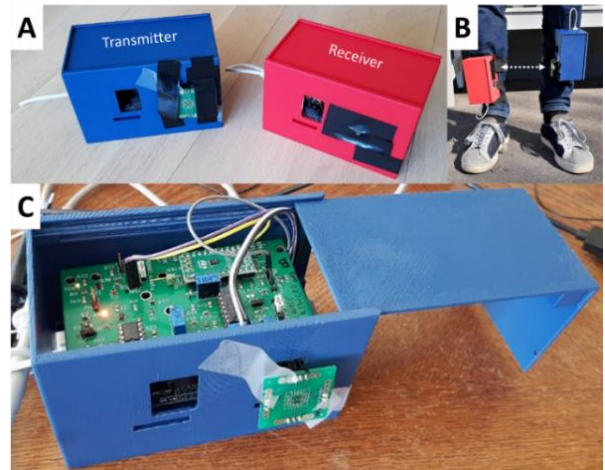

## MULTI-PURPOSE GESTURE RECOGNITION SYSTEM

Purely wearable system for motion tracking and gesture recognition is developed by project partners JKU and LCM. It uses ultrasound transducers from another project partner Infineon. The system focus on arm gesture detection. The system is based on distance estimation of the limbs (arms) via ultrasound (US) time of flight measurements where US transducers are worn on the torso and on the arms respectively.

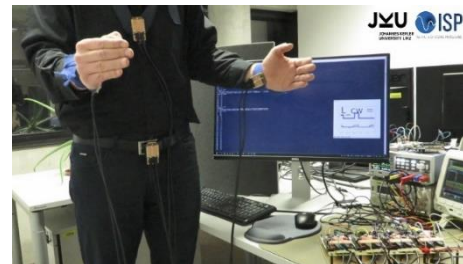

To explore the capabilities of the US transducers two methodologies are investigated. The first methodology is based solely on US transmission and communication, whereas the second methodology additionally uses RF-transmissions to allow synchronization of the US transducers worn on different parts of the body.



You can look forward to the last newsletter with summary of the whole project. For more information about the project see our website: [SILENSE.eu](http://SILENSE.eu).